

CENTRIFUGAL FAN VBM9

SINGLE INLET CENTRIFUGAL FAN

GENERAL CHARACTERISTICS:



MOTOR TYPE: Squirrel cage induction motor IP55 as std

NOMINAL SUPPLY: 380/420VY / 200/240VD 3Ph 50hz
440/480VY / 250/280VD 3Ph 60Hz

OPTIONS: Inlet & discharge guards, Inlet filters, Spigots

MATERIALS: Fancase: Cast aluminium LM6
Impellers: Galvanised sheet steel

FINISHES: Unpainted/Stove enamel (black) as std

MOUNTING OPTIONS: Motor feet or Pedestal

NOISE LEVELS: 80dB(A) Free Air, 1M

WEIGHTS: 16Kgs / 35Lbs

MOTOR VARIATIONS: ATEX, CE, CSA, UL available

[Please note - image above may not be representative of the unit supplied]

PERFORMANCE CURVES:

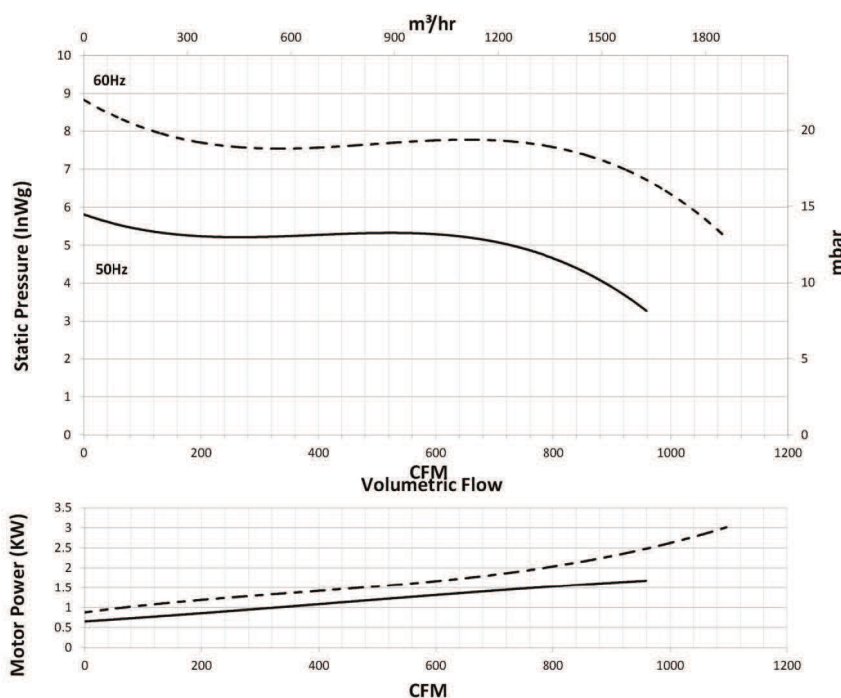

CENTRIFUGAL FAN VBM9

SINGLE INLET CENTRIFUGAL FAN

OUTLINE DIMENSIONS:

[note: motor shown is for 50Hz performance. Motor dimensions for 60Hz operation may vary]

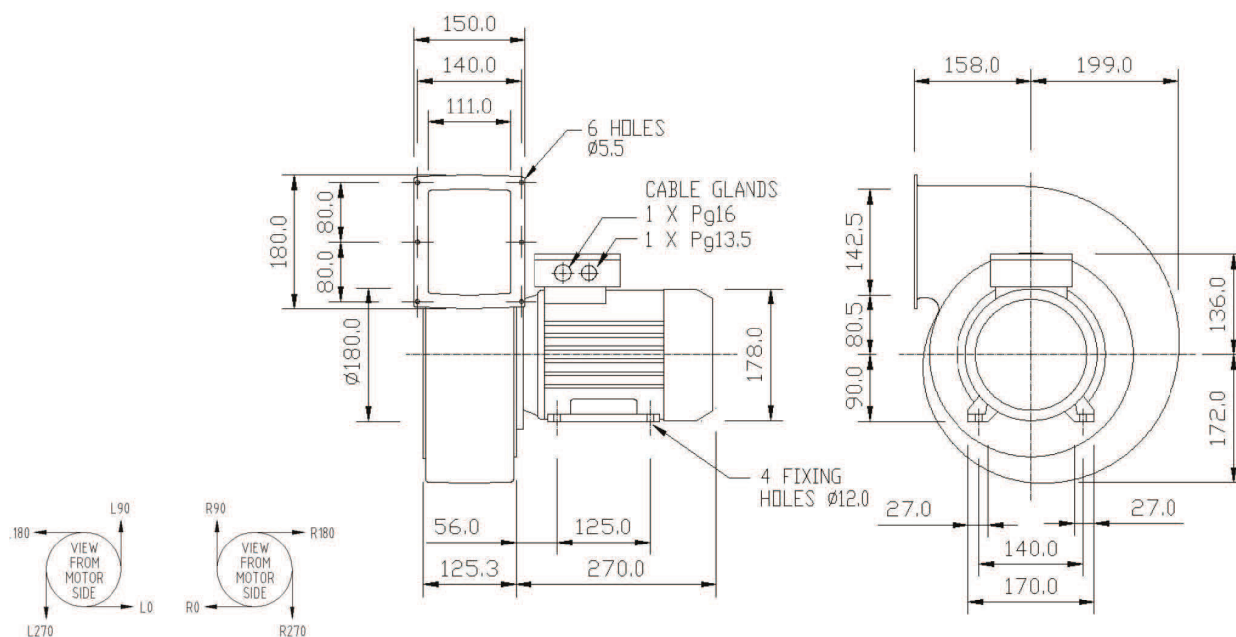

PLEASE NOTE:

1. all drawings measurements are in millimeters (mm)
2. above technical specifications are subject to change